

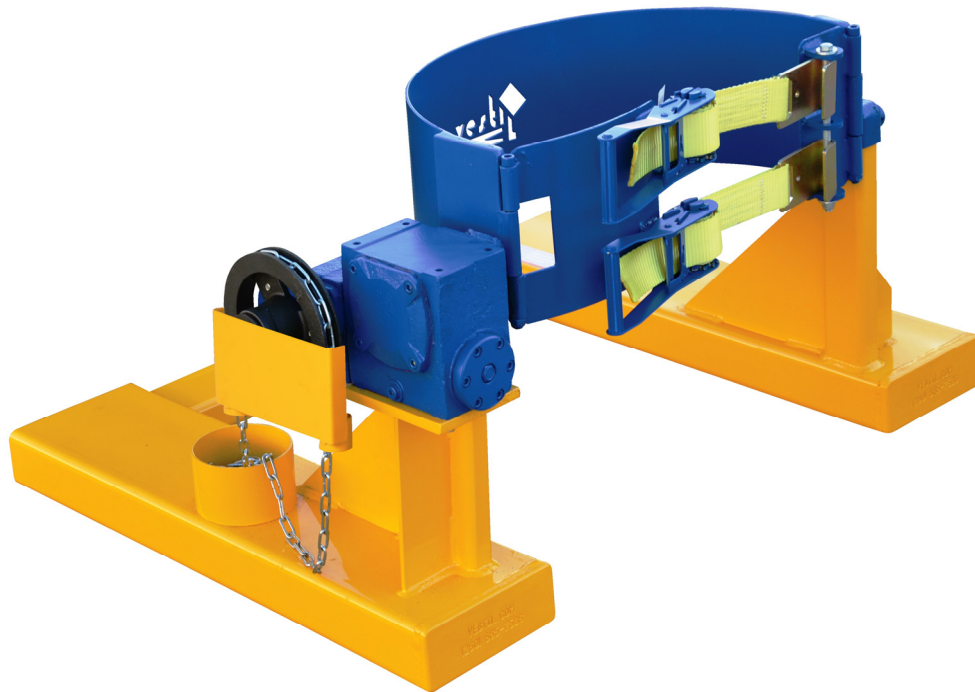

VESTIL MANUFACTURING CORP.

2999 North Wayne Street, P.O. Box 507, Angola, IN 46703
 Telephone: (260) 665-7586 -or- Toll Free (800) 348-0868
 Fax: (260) 665-1339
www.vestilmfg.com e-mail: sales@vestil.com

**DCR-205-20 FORK-MOUNTED DRUM HANDLERS
 INSTRUCTION MANUAL**



Receiving instructions:

After delivery, IMMEDIATELY remove the packaging from the carpet pole in a manner that preserves the packaging and maintains the orientation of the product in the packaging; then inspect the product closely to determine whether it sustained damage during transport. **If damage is discovered during the inspection, immediately record a complete description of the damage on the bill of lading.** If the product is undamaged, discard the packaging.

NOTES:

- 1) Compliance with laws, regulations, codes, and non-voluntary standards enforced in the location where the product is *used* is exclusively the responsibility of the owner/end-user.
- 2) VESTIL is **not liable** for any injury or property damage that occurs as a consequence of failing to apply either:
 - a) Instructions in this manual; or b) information provided on labels affixed to the product.

Table of Contents

Hazard Identification: Explanation of Signal Words.....	2
Safety Recommendations.....	2
Product Specifications.....	3
FIG. 1: DCR-205-20 exploded parts diagram & bill of materials.....	3
FIG. 2: DCR-205-20 dimensions and centers of gravity.....	4
Use instructions.....	4
Inspections.....	5
Maintenance.....	5
Label Placement Diagram.....	6
Limited Warranty.....	7

Hazard Identification: Explanation of Signal Words

This manual uses SIGNAL WORDS to indicate the likelihood of personal injuries, as well as the probable seriousness of those injuries, if the product is misused in the ways described. Other signal words call attention to uses of the product likely cause property damage.

The signal words used appear below along with the meaning of each word:



Identifies a hazardous situation which, if not avoided, **WILL** result in **DEATH** or **SERIOUS INJURY**. Use of this signal word is limited to the most extreme situations.



Identifies a hazardous situation which, if not avoided, **COULD** result in **DEATH** or **SERIOUS INJURY**.



Indicates a hazardous situation which, if not avoided, **COULD** result in **MINOR** or **MODERATE** injury.



Identifies practices likely to result in product/property damage, such as operation that might damage the product.

Each person who assembles, installs, uses, or maintains this product should read the entire manual **in advance and fully understand the directions**. **If after reading the manual you do not understand an instruction, ask your supervisor or employer for clarification, because failure to adhere to the directions in this manual might result in serious personal injury.**

Safety Recommendations:

Vestil diligently strives to identify foreseeable hazards associated with the use of its products. However, material handling is inherently dangerous and no manual can address every conceivable risk. The end-user ultimately is responsible for exercising sound judgment at all times.



If this product is used improperly or carelessly, the operator and/or bystanders might sustain serious personal injuries or even be killed. **ALWAYS** use the product properly:

- *Failure to read and understand the entire manual before assembling, installing, using or servicing the product is a misuse of the product.* Read the manual to refresh your understanding of proper use and maintenance procedures.
- **DO NOT** exceed the maximum rated load (see Label 287 on product; also shown on p. 6).
- Mark your forklift truck to identify the drum carrier attachment and show the approximate weight of the truck and attachment combination at maximum elevation with load laterally centered. Capacity, operation, and maintenance instruction plates, tags, or decals must be changed accordingly.
- **DO NOT** use the DCR until you read and understand the entire manual. Review the manual as frequently as necessary to refresh your understanding of recommended use or maintenance procedures. Maintenance personnel should also read the manual before maintaining or servicing the drum carrier.
- **DO NOT** use the carrier unless you are trained to use it.
- Inspect the drum carrier before each use (see "Inspections & Maintenance" on p. 5). **DO NOT** use the device unless it is in satisfactory condition. If you observe any structural damage (for example, significant damage to either or both fork pockets, the safety chain, or the drum-gripping mechanism), tag the unit "Out of Service" and report the damage to maintenance personnel. **DO NOT** use the carrier until it is restored to normal condition.
- **DO NOT** allow people to ride or play on the drum carrier.
- **ONLY** use the DCR to lift and transport drums. **ALWAYS** confirm that the drum is securely gripped before driving the drum to a new location.
- **DO NOT** leave an elevated drum unattended. Lower the drum to the ground; then disconnect the drum cradle. Back the forklift away from the drum until the drum and drum carrier are completely free of each other.
- **DO NOT** use the DCR if the drum cradle assembly or the cradle closure is damaged or broken. **ONLY** use the carrier if the cradle and closure function properly.
- **DO NOT** attempt to resolve any problems with this product unless you are certain that it will be safe to use afterwards.
- **DO NOT** modify the carrier in any way. **Unauthorized modifications automatically void the limited warranty (see p. 7) and might make the product unsafe to use.**

Product Specifications:

Model	Maximum Rated Load		Drum Type (volume and construction)	Net Weight in Pounds (kg)	Actuation
	Full barrel:	Half-full barrel:			
DCR-205-20	2,000 lb. 909kg	1,000 lb. 454kg	55 gallon Steel	187 lb. 85kg	Manual chain; 15 revolutions of chain wheel provides 90° of drum rotation; 2-stage worm gear speed reducer ratio 60:1

FIG. 1: DCR-205-20 exploded parts diagram and bill of materials

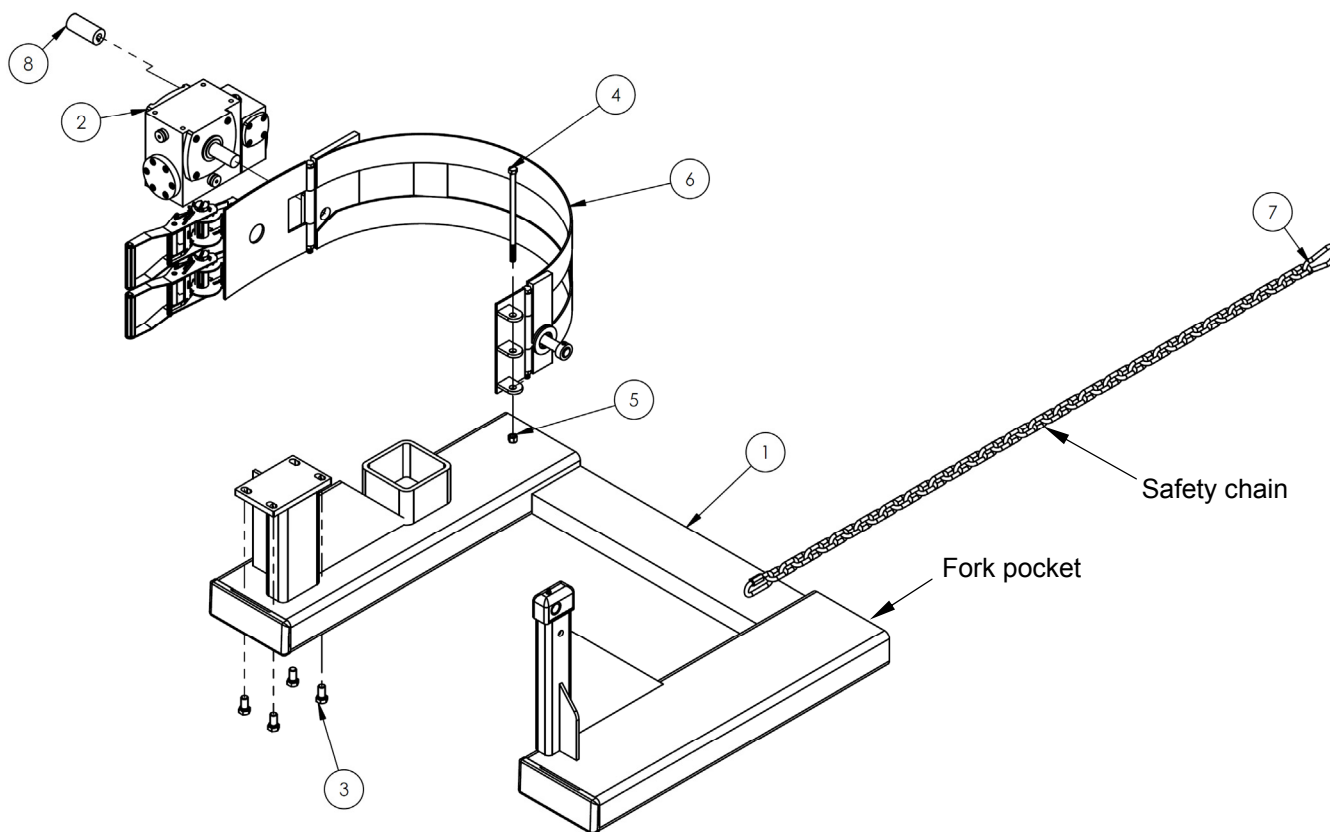

Item no.	Part no.	Description	Quantity
1	09-514-115	Frame, weldment, DCR-20-20	1
2	09-141-001	Reducer, gear	1
3	11205	$\frac{1}{2}$ in. – 13 x 1in. HHCS #2 zinc-plated bolt	4
4	11129	$\frac{3}{8}$ in. – 16 x 8in. zinc-plated hex bolt	1
5	37024	$\frac{3}{8}$ in. lock nut	1
6	09-002-004-002	Drum cradle assembly (without gears)	1
7	08-145-041	$\frac{9}{16}$ in. snap hook	1
8	09-145-033	Crank adapter	1

FIG. 2: DCR-205-20 dimensions and centers of gravity

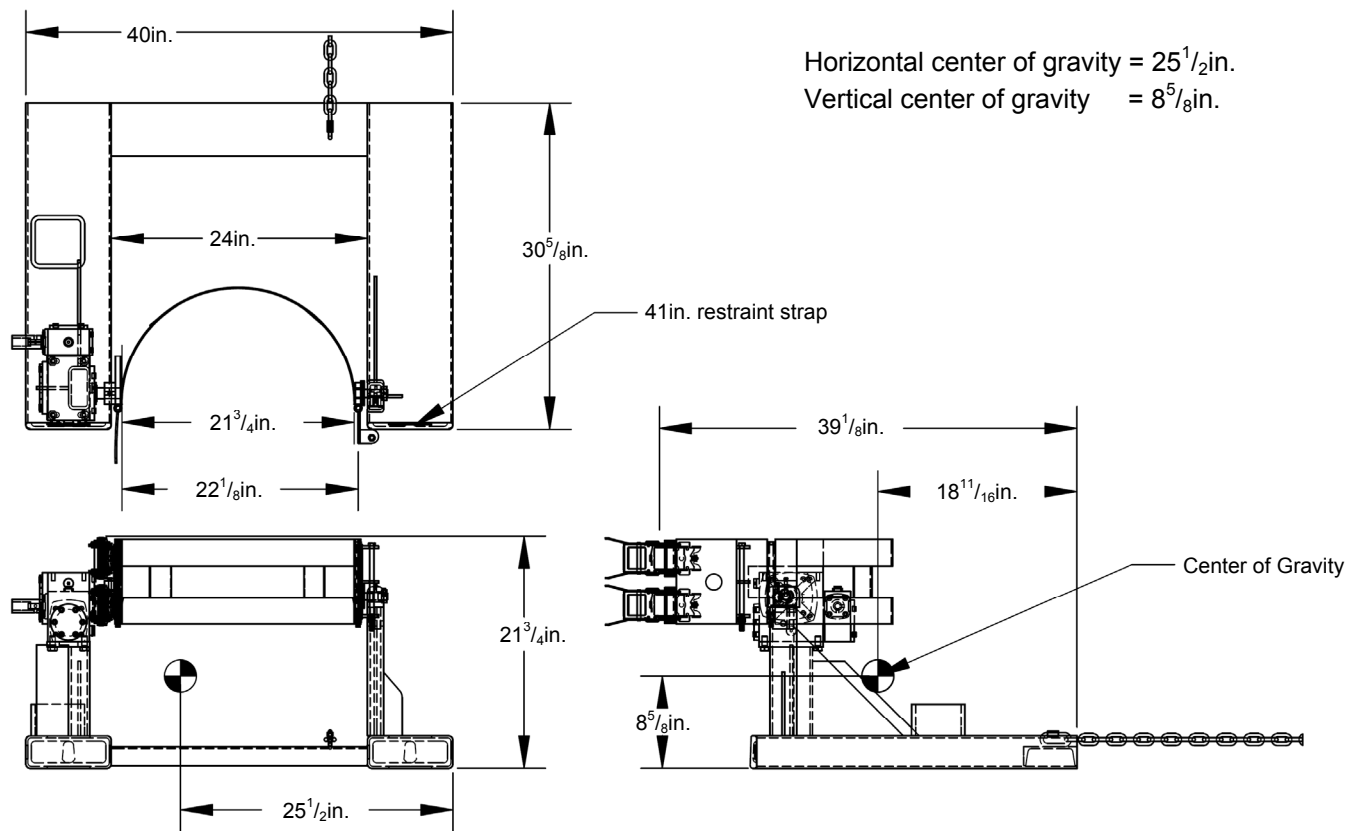

Use instructions:

- Step 1: Adjust the separation between fork truck tines to align with the fork pockets (see FIG. 1 on p. 3) of the drum carrier. Tines should be at least $25\frac{1}{2}$ in. apart (inside edge to inside edge). Drive forward to insert the tines into the fork pockets. Drive forward until the ends of the tines contact the ends of the fork pockets.
- Step 2: To prevent the carrier from sliding off the forks, attach the safety chain (FIG. 1 on p. 3) to the carriage of your lift truck *without slack*.
- Step 3: Unhook the ratchet straps from the hook bolt. If the straps are too tight to unhook from the bolt, pull up on the release lever and pull on the strap until there is adequate slack to unhook the straps from the hook bolt. Swing open the hinged parts of the drum cradle. Drive toward the drum with tines just a few inches above the floor.
- Step 4: Secure drum in the cradle with the ratchet straps. Move the handles back-and-forth to tighten the straps against the side of the drum.
- Step 5: Extract the chain from the storage compartment. Place the end of the chain in the forklift cabin where it is easily accessible to the lift operator. Make sure that the drum is vertical.
- Step 6: Raise the forks a few inches from the ground and transport the drum to the dumping location. To dump the contents of the drum, hold both arms of the chain. Maintain control of the speed at which the drum rotates by grasping one arm of the chain and while pulling the other arm towards you. When the drum is empty, rotate it back to the vertical position.

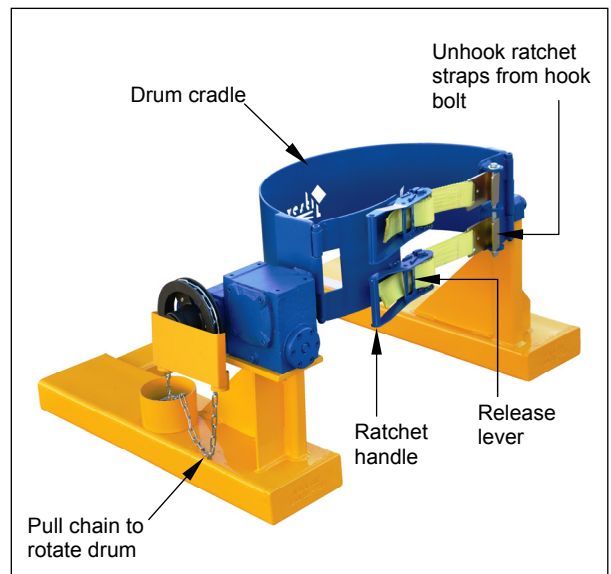

Inspections & Maintenance: perform the inspections explained below and maintain the drum carrier as described to ensure that the unit is and remains in normal, safe operating condition.

⚠WARNING If a problem is discovered during an inspection, restore the drum carrier to normal operating condition **BEFORE** using it again. DO NOT use the carrier if it is structurally damaged in any way. Structural damage includes, but is not limited to, cracked welds, warping or deformation of the frame, drum cradle.

Inspections:

Before each use, including first use, inspect the listed components:

1. Safety chain and snap: confirm that the spring latch automatically closes securely against the hook. DO NOT use the carrier if any part of the safety chain mechanism is damaged.
2. Product labels: all labels should be readable and located as shown in the “Label placement diagram” on p. #. If a label(s) is unreadable or missing, contact Vestil to order a replacement.

Periodic inspection (at least 1 time per month):

1. Fasteners (hardware):
 - Bolts, nuts, washers, and snap hooks
 - Chain that rotates the drum cradle.
2. Fork pockets: confirm that each pocket is structurally sound, not corroded, and free of rust. Only use the carrier if the fork pockets are in normal condition.
3. Welds: confirm that all welds are intact.
4. Drum cradle, ratchet straps, ratchet handle, and supporting frame: must be undamaged. For example, no structural deformation, warps, or cracks.
5. Gear reducer (item no. 2 on p. 3), chain wheel, & pivot points: rotate the drum cradle to confirm normal operation of the gear reducer and chain wheel. Lubricate pivot points periodically.
6. Cradle hinges: confirm that hinges operate normally. Lubricate all hinges at least once per month or more frequently if the drum carrier experiences heavy usage.
5. Overall condition of drum carrier: the structure should be clean, square and rigid, and free of rust and corrosion. Remove dirt and debris. Do not use the carrier if the supporting frame and/or one or both ratchet straps are excessively torn, rusted, or otherwise damaged.

Maintenance:

NOTICE Proper use, maintenance, and storage are essential for this product to function properly.

- Always use the carrier as described in the instructions in this manual and consistently with any training relevant to forklift attachments.
- ONLY install replacement parts supplied or approved by the manufacturer.
- ALWAYS store the DCR in a dry location. If necessary, elevate the carrier by storing it on a pallet, storage rack, etc. to prevent damage that might occur if contact with water or corroding liquids occurs.

Step 1: Tag the unit, “Out of Service.”

Step 2: Remove any dirt or other matter from all surfaces.

Step 3: Conduct a “Periodic” inspection. If deformity, corrosion, rusting, or excessive wear of structural members is found, DO NOT use the product.

Step 4: Perform all necessary adjustments, replacements and/or repairs but DO NOT modify the carrier.

⚠WARNING DO NOT use the unit if adjustments and/or repairs are incomplete! DO NOT modify the drum carrier in any way.

An “adjustment” is a simple correction that restores the unit to normal operating condition, such as tightening loose fasteners, or removing dirt or other debris from the surface. “Repair” refers to removing worn parts and installing replacement parts.

A “modification” is a change that alters the drum carrier from normal operating condition, like bending the structural members or removing a part or several parts. **NEVER** modify the unit without the express, written approval of Vestil. Modifications might make the device unsafe to use and *automatically* void the limited warranty.

Step 5: Make a dated record of any repairs, adjustments and/or replacements.

Label Placement Diagram:

The product should always be labeled as shown in the diagram below. Replace any label that is damaged or not easily readable.

Label 218: Fasten safety chain to carriage (applied to frame crossbar close to safety chain)

⚠ WARNING	⚠ ADVERTENCIAS
Improper use might result in death or serious personal injury. Attach device to fork carriage with safety chain/strap. <ul style="list-style-type: none"> • Drive lift truck forward until forks contact ends of fork pockets. • Chain/straps must not be able to disconnect (slide free) from carriage. • Safety chain/strap must be taut. Connect chain/strap to carriage via shortest line. 	El uso impropio puede resultar en muerte o heridas personales. Atar aparato al mástil del montacargas con cadenas/correas. <ul style="list-style-type: none"> • Maneje el montacargas para adelante hasta que las cuñas hagan contacto con la orilla del bolsillo de las cuñas. • La cadenas y correas no deben de deslizarse (soltarse) del mástil del montacargas. • La cadena/correa de seguridad debe de estar apretado. Asegure la cadena/correa al mástil via la ruta mas corta.
	218 rev 0910

Label 287: Model, serial no. capacity (apply to frame crossbar)

MODEL/MODÉLO/MODELE	_____
STATIC CAPACITY (evenly distributed)	_____ lbs.
LA CAPACIDAD CONSTANTE (distribuida uniformemente)	_____ kgs.
CAPACITÉ STATIQUE (distribuée régulièrement)	_____ kgs.
SERIAL/SERIE/SÉRIE	_____
	287 REV 0812

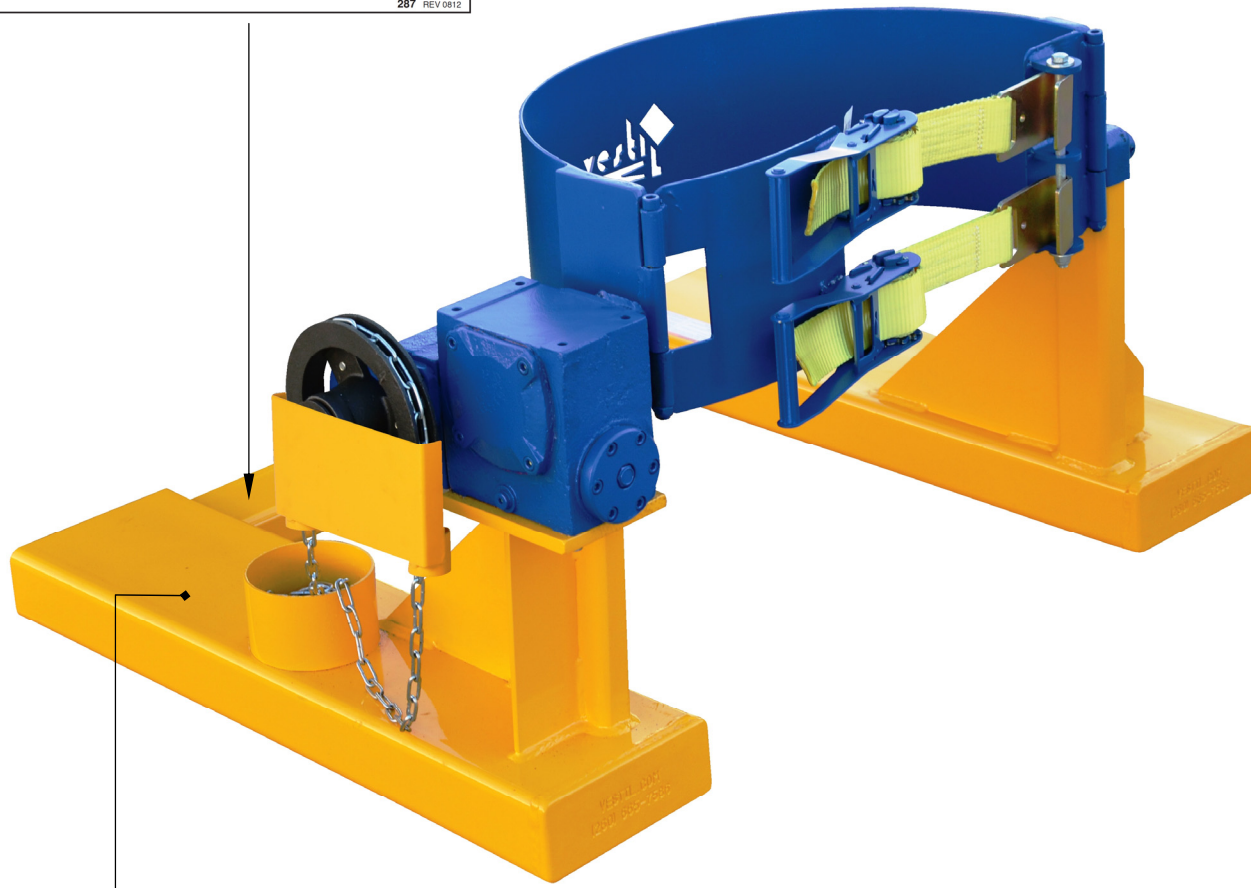

Label 232: Transport barrel in vertical position (On fork pocket near chain cup)

⚠ CAUTION	⚠ ATENCIÓN	⚠ ATTENTION
DRUM MUST BE IN VERTICAL POSITION WHEN MOVING	EL TAMBOR DEBE DE ESTAR EN LA POSICIÓN VERTICAL CUANDO EN MOVIMIENTO	LE BIDON DOIT ÊTRE EN POSITION VERTICALE LORS D'UN DÉPLACEMENT
<small>VESTIL MANUFACTURING CORPORATION • Phone (260) 665-7586 • Fax (260) 665-1339 • sales@vestil.com • www.vestil.com</small>		

LIMITED WARRANTY

Vestil Manufacturing Corporation (“Vestil”) warrants this product to be free of defects in material and workmanship during the warranty period. *Our warranty obligation is to provide a replacement for a defective original part if the part is covered by the warranty, after we receive a proper request from the warrantee (you) for warranty service.*

Who may request service?

Only a warrantee may request service. *You are a warrantee if* you purchased the product from Vestil or from an authorized distributor AND Vestil has been fully paid.

What is an “original part”?

An original part is a part used to make the product as shipped to the warrantee.

What is a “proper request”?

A request for warranty service is proper if Vestil receives: 1) a photocopy of the Customer Invoice that displays the shipping date; AND 2) a written request for warranty service including your name and phone number. Send requests by any of the following methods:

Mail
Vestil Manufacturing Corporation
2999 North Wayne Street, PO Box 507
Angola, IN 46703

Fax
(260) 665-1339
Phone
(260) 665-7586

Email
sales@vestil.com

In the written request, list the parts believed to be defective and include the address where replacements should be delivered.

What is covered under the warranty?

After Vestil receives your request for warranty service, an authorized representative will contact you to determine whether your claim is covered by the warranty. Before providing warranty service, Vestil may require you to send the entire product, or just the defective part or parts, to its facility in Angola, IN. The warranty covers defects in the following *original* dynamic components: motors, hydraulic pumps, electronic controllers, switches and cylinders. It also covers defects in *original* parts that wear under normal usage conditions (“wearing parts”): bearings, hoses, wheels, seals, brushes, batteries, and the battery charger.

How long is the warranty period?

The warranty period for original components is 90 days. The warranty period begins on the date when Vestil ships the product to the warrantee. If the product was purchased from an authorized distributor, the period begins when the distributor ships the product. Vestil may extend the warranty period for products shipped from authorized distributors by *up to* 30 days to account for shipping time.

If a defective part is covered by the warranty, what will Vestil do to correct the problem?

Vestil will provide an appropriate replacement for any *covered* part. An authorized representative of Vestil will contact you to discuss your claim.

What is not covered by the warranty?

1. Labor;
2. Freight;
3. Occurrence of any of the following, which automatically voids the warranty:
 - Product misuse;
 - Negligent operation or repair;
 - Corrosion or use in corrosive environments;
 - Inadequate or improper maintenance;
 - Damage sustained during shipping;
 - Collisions or other incidental contacts causing damage to the product;
 - Unauthorized modifications: DO NOT modify the product IN ANY WAY without first receiving written authorization from Vestil. Modification(s) might make the product unsafe to use or might cause excessive and/or abnormal wear.

Do any other warranties apply to the product?

Vestil Manufacturing Corp. makes no other express warranties. All implied warranties are disclaimed to the extent allowed by law. Any implied warranty not disclaimed is limited in scope to the terms of this Limited Warranty.

